

# DESIGN OF A FERTILISATION MACHINE USING HUMAN URINE FOR VEGETABLES GROWTH: THE PIPICULTEUR

Project managed by the action research program OCAP1 within the LEESU at École nationale des  
Ponts et Chaussées,  
with the support of ADEME and the Seine-Normandie Water Agency

This document was translated quickly. It might contain errors.



March 2026

Writing: Loïc Déchaseaux, Louise Raguet and Fabien Esculier

Translation Loïc Déchaseaux



## Table of Contents

PART ONE: The challenges of using human urine in agriculture and the development of citizen networks.....	5
1. Why promote human urine in agriculture? .....	6
2. The ENVILLE project and the development of citizen networks linked to vegetable farms ..	7
2.1. Citizen networks for the agricultural recovery of human urine .....	7
2.2. Opportunities for citizens' networks.....	8
Part Two: how do we use human urine in agriculture? .....	10
3. Regulatory framework and general recommendations .....	11
4.1. Regulatory framework .....	11
4.2. 'Multi-barrier' logic and human urine hygienisation by storage .....	11
4.3. Protective equipment .....	13
4.4. A special case of organic farming .....	13
4. Specificities of the sanitized urine .....	14
4.1. Manufacture of sanitized urine.....	14
1.1. Nutrient content of the sanitized urine.....	14
1.2. Recommended doses.....	14
1.3. Precautions.....	15
1.4. Methods of application.....	15
5. Existing tools for fertilizing with sanitized urine .....	16
THIRD part.....	20
Design of an injection tool for fertilized urine on raised bed.....	20
6. Why develop a specific machine? .....	21
7. Overview of the tool being developed .....	22
8. Technical description and choices.....	23
8.1. Reuse of a sprayer? .....	23
8.2. tanks(s).....	24
8.3. Pump.....	24
8.4. Teeth.....	25
8.5. Frame .....	26
8.6. Piping.....	27
8.7. Areas for Improvement.....	28
9. Regulation on tools used in agriculture.....	28
9.1. Approval.....	28
9.2. EC certification.....	29
10. Variations of the tool without the on-board tank.....	29
11. Use.....	31

11.1	Preparation of soil .....	31
11.2.	Adjusting the Sanitized urine Injection Rate .....	32
11.3.	Tool operation and sanitized urine flow .....	33
12.	Cost of tool .....	33
FOURTH PART.....		34
Fertilization tests and diffusion .....		34
13.	2024 test campaign .....	35
13.1.	Tests.....	35
13.2.	Results.....	36
13.3.	Collection and awareness of the subject of urine valorization.....	38
Conclusion.....		39
Acknowledgements .....		39
References.....		40

# **PART ONE: The challenges of using human urine in agriculture and the development of citizen networks**

# 1. Why promote human urine in agriculture?

## 1.1. A nutrient-rich resource lost in waste water

Urine is rich in nutrients (nitrogen, phosphorus and potassium in particular), which are essential for plant growth. Its use as an agricultural fertilizer ensures sustainable agriculture, based on local and sustainable resources. It does not depend on fossil resources (natural gas, minerals).

When the urine is flushed to the sewers, the nutrients are diluted in the waste water. However, urban sanitation systems allow only a low level of recycling of these nutrients (Starck 2024). Furthermore, despite progress in recent decades, the effectiveness of waste water collection and treatment remains limited; nitrogen and phosphorus from urine still cause significant pollution in our waterways (Starck 2024). Urine collection and use therefore reduce the environmental pressure on rivers. Furthermore, urine - unlike faecal matter - presents little biological health risk, which makes it easier to collect and use in agriculture.

## 1.2. Water saving

The flush toilet is the system most often used to remove our excretes (urine and faeces). In France, all flushing operations account for around 20% of domestic water consumption, i.e. 750 million cubic meters per year.

Climate change is leading to more and more droughts, and in 2022, in France, "more than 2,000 municipalities experienced water supply disruptions or tensions during the summer of 2022" (BERTRAND et al. 2023).. In this context, the comfort of flushing can be called into question.

## 1.3. A few key figures (according to (Fabien et al. s. d.) Esculier et al., 2022):

Urine from 1 person for one year = about 500 m<sup>2</sup> of fertilized fields.

- 25 million baguettes of bread a day could be prepared if the production of urine from all over the Île-de-France (Paris area) were used to fertilize wheat. (Pipi baguettes is the new oui oui baguettes !!)
- As the sewerage systems in the Paris region only remove around 60% of the nitrogen in the waste water, it is as if 4 million inhabitants of this region were sending their urine nitrogen into the Seine.
- Greenhouse gas emissions related to the feed-excretion system are divided by 3 by the collection of urine and its recovery in a field within 100 km
- 20% of household water consumption is accounted for by flushing

## 1.4. The OCAPI research-action program

The Enville project is supported by the action research program OCAPI, within the LEESU (Water, Environment and Urban Systems Laboratory) at the Ecole nationale des ponts et chaussées. This program aims to study and support the transformation of urban food/excretion systems in a context of ecological and solidarity transition. This interdisciplinary program focuses on technical, agronomic, health, sociological and cultural issues related to the agricultural exploitation of human excretes (<https://www.leesu.fr/ocapi/>). It is supported in particular by the Seine Normandy Water Agency, the ADEME, as well as many other technical and financial partners, mainly public ones.

## 2. The ENVILLE project and the development of citizen networks linked to vegetable farms

### 2.1. Citizen networks for the agricultural recovery of human urine

Numerous projects for the separate collection of urine have been developed in France in different contexts (schools, office buildings, flat buildings, entire neighborhoods, etc.). The projects that have been developed for housing are essentially new constructions. This raises the question of mobilising the urine deposits from existing housing, given that the renewal of the city is only around 1% per year. In addition, most projects do little or no mobilization of future users or managers, who are then required to implement a urine recovery system (urine separation toilets, collection networks, drainage systems, etc.), which they will have to take over for the proper functioning of the system. We therefore wished to develop a project intended for existing housing, in a low-tech perspective, easily appropriated by its users and which mobilizes them from the early stages of design.

Furthermore, within the OCAPI program, we receive requests from citizens who, discovering the fertilizing value of their urine and the challenges of a circular feeding/excretion system, ask us about the possibility of collecting their urine at home and using it in agriculture “close to home”.

For example, the OCAPI program has developed the ENVILLE (“Human fertilizer for cities”) project, which explores the possibilities of developing “citizen” networks for the valorization of urine, intended for inhabitants equipped with conventional flush toilets. These pathways are based on the participants’ desire not to dilute and lose their urine in the water of the flush, but to collect it “outside the toilet flush”, in order to enhance it in agriculture.

In concrete terms, this project has made it possible to develop an operational network within an AMAP<sup>1</sup>, between a group of inhabitants who collect their urine at home and a farm which then collects the urine in order to produce a fertilizer (FIG. 1). This network has been operating since January 2024 and is based on a set of protocols and devices that are relatively easy to implement, which we have detailed in several publications on the OCAPI program website: <https://www.leesu.fr/ocapi/les-projets/enville/>. Through this dissemination, we hope to enable other communities of inhabitants or associations to replicate similar networks, and we are ready to provide support for these new projects.



Figure 1: Operation of the citizen network for the agricultural valorisation of urine developed within the framework of the ENVILLE project, between inhabitants who are members of an AMAP and the partner farm that delivers the vegetables to the AMAP.

<sup>1</sup> AMAP (Association for the Maintenance of Peasant Agriculture) = an association of consumers who contract with a market gardener for a whole year the supply of vegetables on a short-circuit every week (Community-supported agriculture)

The urine collected so far in this “demonstration” route has been applied to “test” areas on the partner farm. Through these initial fertilization tests, it appeared to us that it was essential to carry out specific work on the application tools for *urine-fertilizers* (= fertilizers produced from human urine), which is the subject of this report.

## 2.2. Opportunities for citizens' networks

### Involvement of market gardening and farming farms

Agricultural value chains for human urine can involve all types of agriculture: large grain farms as well as small and medium-sized *farmers'* market gardening farms, which distribute their production mainly on short-circuit. It is mainly the context, specific to each branch, that will define the outlets.

It seems quite likely that the development of citizen networks will rather involve farmers' market gardening farms, since they already have strong links with their consumers, who are themselves committed to agro-ecological agriculture. This is why, in order to encourage the emergence of citizen networks, it seems essential to propose practical and easily accessible means of spreading crops in this type of agricultural context.

### Production of urinofertilizers in the context of a citizen network

Once the urine has been collected, there are different methods for converting the urine into a “urinofertilizer”. These methods are more or less simple to implement, and they should be chosen according to the context of the branch. Some processes are only conceivable for relatively industrial scale deployments. We detail all the urinofertilizers in a specific document, available on the OCAPI program website: [https://www.leesu.fr/ocapi/wp-content/uploads/2024/12/fiches\\_agrocap\\_i\\_numerique\\_BD-compress%C3%A9.pdf](https://www.leesu.fr/ocapi/wp-content/uploads/2024/12/fiches_agrocap_i_numerique_BD-compress%C3%A9.pdf)

Citizens' networks for the agricultural use of urine are developing in rather low-tech situations, where, a priori, investments must be as low as possible and the arrangements must be as simple as possible to appropriate. Thus, the most likely transformation (for the moment) to be deployed in the context of citizen networks is **the hygienisation by storage combined with the “multi-barrier” logic**, according to the recommendations of the World Health Organisation WHO 2012.. We detail this in the second part “How to use human urine in agriculture”. The product obtained is called slurry, and it has application constraints to avoid strong odours at the time of application and a potential loss of nitrogen, because it is present in a particularly volatile form.

However, it could be envisaged to *stabilise* the urine by nitrification by installing a [Pitribon](#) filter. It is a low-tech and relatively simple implementation system proposed by the Aneco association, which puts on line the resources needed to build its own filter: <https://an-eco.ch/solutions-promues/>. The advantage of urine stabilisation is to obtain a urinofertilizer whose nitrogen form is not volatile, unlike the slurry<sup>2</sup>. The reduction of volatilisation limits the odours during application and the nitrogen losses. Stabilisation may therefore facilitate application conditions. We have not yet worked with this type of urinofertilizer, but we hope to be able to test its implementation in the future as it seems potentially adapted to the context of the citizen networks. Other types of low-tech process are also possible (2).

---

<sup>2</sup> However, it should be noted that the process is liable to cause emissions at the time of treatment, in particular nitrous oxide, and that a complete study of this process should be carried out, which to date does not exist to our knowledge.

### Tools available for spreading sanitized urine

Since the citizen will produce sanitized urine, we would like to focus on the development of suitable tools for the application of this type of product. However, the application of sanitized urine presents constraints, in particular to limit volatilization but also to avoid contact with the aerial parts of the plants. These constraints are detailed in the second part “How to use human urine in agriculture”.

Thus, still with a view to supporting the development of the citizen networks and facilitating the application of sanitized urine in the context of vegetable and peasant farms, we wished to identify the tools available for fertilizing with human urine. We have also sought to identify the most likely technical routes. This census has led us to note the absence of suitable tools for certain application contexts and that is why we have also begun work on the design, to offer vegetable farms a tool to apply sanitized urine to their crops.

## **Part Two: how do we use human urine in agriculture?**

### 3. Regulatory framework and general recommendations

#### 4.1. Regulatory framework

The specific fertilizing materials derived from a treatment of human urine and making it possible to utilize their nutrients are called urinofertilizers. At present, there are no specific rules on the use of urine fertilizers in agriculture. The regulations on sanitation make it difficult to take into account the issues of circularity, cleanliness and sobriety associated with the management of urine and human faeces.

As the practice is emerging<sup>3</sup>, it is logical that the existing regulations do not explicitly provide for the use of urinofertilizers. The absence of a regulatory framework does not mean a ban and should not necessarily hinder the development of separation schemes at source, as can be seen from the emergence of a number of experimental networks in France, some of which are even large.

At least five possible regulatory frameworks have been identified for the use of urine fertilizers:

- Compliance with a European regulation. At present, no European regulations have been identified which may concern urinofertilizers;
- The Marketing Authorisation (MA). At present, no actor has requested an MA for the fertilizers envisaged in the Enville project;
- A specifications issued by the Ministry in charge of Agriculture. At present, the Ministry of Agriculture has not drafted any specifications on the use of fertilizers;
- Compliance with a standard. The possibility of using this regulatory route is currently under consideration;
- The spreading plan under waste status. By default, this port can be used. The application of urinofertilizer is then regulated by the Water Act (section 2.1.4.O *a priori*). The Water Act declaration is required for projects that use more than 1 tN/year (i.e. approximately 160 m<sup>3</sup> of office/habitat urine or 250 m<sup>3</sup> of event-related urine).

The Arceau IdF Thematic Working Group has drafted a specific note on regulatory issues. You can consult it on the Ocap website for a more complete legal analysis of the subject ([Bibliography](#) →[Library](#)) ARCEAU 2023..

The international reference text for the use of urine in agriculture is the World Health Organisation report on the safe use of human excretes WHO 2012.. This report states in particular that urine storage constitutes a treatment operation allowing urine to be used without danger to human health, also adopting a multi-barrier logic. The Stockholm Environment Institute has also published a guide to the use of urine in agriculture (Richert, Gensch, and Jönsson 2011).. These are the two main reference documents that we apply for the sectors developed in the Enville project.

#### 4.2. 'Multi-barrier' logic and human urine hygienisation by storage

For the technologies developed in the framework of the ENVILLE project, we apply the “multi-barrier” method recommended by the World Health Organisation for the use of human excretes in agriculture WHO 2012.. This is a set of urine collection, storage and application conditions which make it possible to ensure a practice with a negligible risk to the health of consumers and operators.

---

<sup>3</sup> Although the practice is now emerging, it is not new: fertilisation of crops with human excreta, especially collected from cities, was practised for centuries. It was gradually abandoned with the arrival of synthetic fertilisers at the beginning of the 20<sup>th</sup> century, then forgotten.

Each of the proposed barriers reduces the risk and can be added to achieve a maximum level of precaution. The barriers are as follows:

#### Separation at source (urine collection method)

We recommend the recovery of urine from stationary and add-ons WHO 2012.. The main health risk associated with the use of human urine in agriculture is cross-faecal contamination. This risk is therefore very low in the case of collection in urinals or cans.

#### Storage of urine

The transformation of urine that takes place during storage is a treatment in itself. The spontaneous conversion of urea into ammonia causes a pH of around 9 (Udert, Larsen, and Gujer 2006).. The combination of the high pH and ammonia solution provides a reduction in most pathogenic microorganisms that may be present in the urine, even in the event of cross-faecal contamination WHO 2012..

The storage time required varies from 1 to 6 months: it depends on the risk of contamination, the storage temperature and the crop on which the urine will be applied (see section “Restricting fertilized crops”).

In order to guarantee a storage time allowing hygienisation of the urine, we carry out a follow-up of the dates of filling of the tanks. For the six-month storage period to be respected, the tank must not have received any additional urine input during the entire storage period.

#### Application technique

The application of urine to crops also helps to reduce the health risk associated with human urine fertilization. Urine should be applied to the soil and not to edible parts of plants. If possible, urine should be covered or buried in the soil immediately after application (e.g. covering with mulch or grass clipping), which also increases fertilizing efficiency, and reduces ammoniacal loss and odour (Richert, Gensch, and Jönsson 2011)..

In our case, we will put urine in the soil before sowing or planting. This method appears to guarantee the safest possible structural use of the slurry.

#### Restriction of fertilized crops

If the urine has been treated by storage (6 months at 20 °C) and the other barriers are met, it is not necessary to apply specific restrictions to urine-fertilized crops.

However, if you are spreading urine that has been stored for less than six months at 20°C, it is necessary to restrict the practice to “non-sensitive” cultures:

- Crops that are not edible (e.g. ornamental flowers)
- Crops which are solely consumed processed or cooked (for example cereals, potatoes, aubergine, etc.)
- Fruit trees: distance between the soil and the harvested part of the crop.

### Waiting period before harvest

A delay between the last application of urine and the harvest allows an additional barrier to be added to reduce the health risk since any pathogens will be destroyed by external factors such as UV radiation, drying and temperature WHO 2012..

In particular, if the crops are to be consumed raw, a waiting period of one month must be allowed between the last fertilisation and the harvest (WHO 2012; Richert, Gensch, and Jönsson (2011)..

### 4.3. Protective equipment

Although there is no high risk associated with the application of treated urine, it is recommended that agricultural workers wear appropriate protective clothing, especially to protect themselves against the risks associated with direct contact (gloves, shoes, dedicated clothing and changed after handling the skinny).

For people who regularly work with sanitized urine and especially in a closed environment, we recommend the use of anti-ammonia masks.

### 4.4. A special case of organic farming

Organic farming has a major stake in the supply of nutrients and could find itself facing a dead end in fertilizing its soils (Nesme et al. 2016).. In a study examining the possibility of producing all the world's food according to the specifications of organic farming (Muller et al. 2017)However, the supply of nitrogen is presented as an important limiting factor. This could be offset, for example, by the use of human urine, which contains most of the nitrogen, phosphorus and potassium we ingest (Billen et al. 2021)..

Human urine may be a good starter during winter outbreaks when temperatures are still too low for soil biological activity to mineralize organic matter.

However, to date, it is legally unclear whether it is possible to use urinofertilizers in organic farming. According to the regulations, a fertilizer is authorized for organic farming if it fulfils two cumulative conditions: be lawfully placed on the market (or be exempted as notified in Article L255-5 of the Rural and Maritime Fisheries Code) and be included in Annexe II to Regulation 2018/848. At the moment, it is not clear whether or not those conditions are legally met by the urinofitants.

That said, non-factory-farmed urine and animal faecal material are well permitted and some consider that human excreta could fall into the same category (especially if it is from the farm's home), but this interpretation remains to be confirmed.

Based on a study of various relevant stakeholders (Marandet and Esculier 2022)However, two main obstacles limit the introduction of fertilizers into organic farming. The first concerns uncertainties with regard to micro-pollutants and medicinal residues contained in human urine. It should be noted that organic farms, and *a fortiori* non-organic but non-industrial farms, use medicinal treatments and that the spreading of their effluents is authorized in organic agriculture. The second obstacle relates to the high level of nitrogen in the mineral (and inorganic) form of the urinofertilizers. It should be noted that the excretion of ruminant urine or poultry manure in the field is not prohibited in organic agriculture, nor animal manure or digestate from methanizers whose mineral nitrogen contents may be similar to those of manure.

The FNAB (Fédération Nationale de l'Agriculture Biologique) is currently studying the appropriateness of using human urine in organic farming and the conditions that would allow this practice to be included in the certification specifications, in view of current practices (FNAB 2024)..

## 4. Specificities of the sanitized urine

### 4.1. Manufacture of sanitized urine

Sanitized urine (Lisain in french) (Esculier 2018) ) is a urinofertilizer obtained by storing urine in a closed container. During storage, urea is hydrolyzed to ammoniacal nitrogen, increasing the pH of the urine to around 9. These conditions allow for the reduction of pathogens that may be present in the urine.

At this pH, the nitrogen in ammoniacal form volatilizes strongly in the atmosphere. It is therefore essential to close the storage tank properly and to avoid ventilating it, otherwise some of the nitrogen will be lost and very strong odours will appear.

It is also for this reason that it is recommended to bury the slurry or cover it after application (see "Method of application" below).

### 1.1. Nutrient content of the sanitized urine

Stored urine is a liquid, mostly mineral fertilizer containing, in addition to nitrogen, a certain amount of phosphorus, potassium, sulphur and micronutrients (Etter, Udert, and Gounden 2015).. Concentrations vary according to the context. **A typical value of 'NPK' of the slurry is 0,6/0,05/0,1** (Martin et al. 2020)..

The nutrients contained in the manure are mainly in ionic form and their bioavailability is comparable to that of synthetic fertilizers (Fabien et al. s. d.).. The nitrogen present in the slurry is mainly in the ammoniacal form (9).

### 1.2. Recommended doses

Slurry can be applied on most crops, and in particular those with a high demand for nitrogen (spinach, cabbage, chard, corn, wheat, etc.). The basic figure that is recommended in several books is **2L/m<sup>2</sup>**, but can be refined according to cultures (de Looze 2018; Richert, Gensch, and Jönsson (2011)..

According to Renaud de Looze's book "The urine of liquid gold in the garden" (de Looze 2018), here are two possible methods of applying the lisain:

- Method 1: once before planting

In addition to the usual modification (compost, manure, etc.), incorporate the undiluted slurry into the soil 15 days before planting (dosage in FIG. 2).

- Method 2: under cultivation

In addition to the usual amendment if necessary (compost, manure, etc.), dilute the slurry at a rate of 5% (1 share of slurry for 19 parts of water) and apply the slurry every 2 or 3 weeks, at a rate of 10 litres of slurry-water mixture per m<sup>2</sup>.

Bring fertilization especially at the beginning of plant growth and stop the application of slurry 1 month before harvest if the crops are consumed raw.

Catégorie	Plante	Nombre de litres d'urine à épandre par m <sup>2</sup>
Usage intense	Chou et blette	4
Usage soutenu	Céleri	3
	Carde	
	Concombre	
	Aubergine	
	Poireau	
	Poivron	
Usage moyen	Artichaut	2
	Asperge	
	Betterave	
	Brocoli	
	Ail	
	Oignon	
	Pomme de terre	
	Epinard	
	Courge	
	Tomates	
	Courgettes	
Usage modéré	Carottes	1
	Persil	
	Radis	
	Salade	
	Echalote	
	Fraise	
	Navet	
Moins utile	Pois, fèves	0,5
	Petits pois	

Figure 2 :: Total amount of slurry (before dilution if any) to be applied, depending on the crops. According to (de Looze 2018)..

Numerous scientific publications describe the fertilizing efficiency of urine, particularly in comparison with other available organic or mineral fertilizers, on all types of crops (cereals, fruit trees, vegetables, meadows, etc.). A detailed list can be found in Martin *et al.*, 2020 (Martin *et al.* 2020)..

### 1.3. Precautions

If the sensitivity of the culture to the slurry is not yet known or experienced, it may be better to apply the slurry either before sowing<sup>4</sup> (15 days before) or at a certain distance from the plants, this in order to prevent the roots of the plant from completely immersing in the applied slurry.

### 1.4. Methods of application

The recommended method of applying sanitized urine is landfill. Since ammonia is very volatile, it must be covered with earth (or other) to limit as much as possible the losses in the atmosphere.

For drip irrigated crops, it is also possible to use this system for fertilization. When the drip is under mulch or tarps, the volatilization is all the less important.

Sanitized urine has characteristics similar to those of methanizer digesters (liquid product, nutrient concentration, risk of volatilization, etc.) and sanitized urine. It is therefore possible to follow the same recommendations as for applying digestate (Bes de Berc *et al.* 2021) or sanitized urine.

<sup>4</sup> During the 2024 tests, we were unable to meet this deadline and we did not notice any problems with lifting the seedlings.

## 5. Existing tools for fertilizing with sanitized urine

As part of the development of the “demonstration” citizen network, we have identified several tools available for the partner farm to carry out fertilization using manure in a greenhouse, on beds or in the field. In addition, the Rich Earth Institute<sup>5</sup> has also published a guide to the use of human urine in agriculture for farmers (link <https://ricearthinstitute.org>).

### Fertilization with irrigation

Dilute sanitized urine can be applied in irrigation water if it is dropwise (excluding sprinklers). This technique appears to be the simplest to implement in contexts where a drip irrigation network is already in place. This can be done with a venturi fertilizer injector or a metering pump. These systems greatly facilitate the spreading since it is sufficient to carry out the assembly once with a bypass to the irrigation network to pass through the injector or the pump which takes directly into the tank of sanitized urine which can be stored nearby.

The venturi fertilizer injector works mechanically. The irrigation water inlet pressure allows the fertilizer to be driven and diluted automatically. The injection flow rate (and therefore the dilution %) depends on the irrigation flow rate.

The metering pump takes the amount of fertilizer programmed for injection into the irrigation system. As part of the Enville project, we have not tested this type of pump.



*Figure 3 :: Fertilisation with sanitized urine, diluted by venturi fertilizer injector and drip network. Left: tank of sanitized urine near the greenhouses. Right: Venturi fertilizer injector connected to the irrigation network and dipped in the liquid manure tank.*

Concerning the dilution ratios, we noted a great diversity of practices: this varies from 50% (a share of lisain for a share of water) to 5% (a share of lisain for 19 shares of water). Dilution could allow better assimilation of fertilizer by plants (according to Renaud de Looze (de Looze 2018)). Another advantage of dilution is that it reduces the risk of volatilization, burning and salinisation of the soil.

However, dilution of the sanitized urine in hard water may result in the creation of solid deposits that can clog drip (Agricultural Uses for Urine Fertilizer 2021) Zandee, Etter, and Udert (2012).. It is therefore recommended that the irrigation system be rinsed after application of dilute sanitized urine. It is possible to reduce clogging by sending water into the drip network, then liquid manure and then water again. The application of the dropwise sanitized urine is rather appropriate as this

<sup>5</sup> The Rich Earth Institute, based in the United States, is both a research institute and a community of producers of urinofertiliser. They created the first citizen network with a voluntary urine supply point.

system deposits the product directly onto the floor. If the drip lines are placed under a tarpaulin or mulch, it is even better to limit ammonia volatilization.

It is also possible to use the drip irrigation system to fertilize directly with undiluted sanitized urine, using a pump or in a “gravity” mode (see next section).

### “Gravity” drip fertilization

We found projects that simply installed the sanitized urine vats higher up so that the sanitized urine would flow gravitationally through the irrigation system. This is what we have achieved with certain fertilizations, simply by lifting the tank with the fork of the tractor.



Figure 4 :: Fertilisation with undiluted dropwise applied gravity sanitized urine

It can therefore be envisaged to install tanks at height in a durable manner, as described in some experiments (Zandee, Etter, and Udert 2012)..



Figure 5 :: On the left: an experiment on liquid manure fertilisation to measure clogging in different contexts in Nepal (36); On the right: Agronomic experiment of fertilisation with skate in Côte d'Ivoire: raised 1m tank (Tandia 2006)..

### slurry injectors

For ‘field crops’ (wheat, maize, rapeseed, etc.), sanitized urine can be applied with equipment similar to that used to bury slurry or methanizer digestate, for which good spreading practices have been defined (Bes de Berc et al. 2021).. sanitized urine has characteristics very close to these fertilizers (liquid product, nutrient concentration, risk of volatilization, etc.).

### Sprayer and slurry dribble bar

The use of a spray should be avoided for sanitized urine as volatilization is very important. The use of dribble bar is already more appropriate than the atomizer, but volatilization remains high on the soil surface several decades after application. Ideally it should therefore be applied before a rain or - even better - buried after application.

### Self-built spreader

The Rich Earth Institute has a self-built spreader attached to the back of a tractor and with a tank. This model can be used to fertilize vegetable beds or open-field crops. This tool seems very interesting to us but it does not limit the volatilization of the nitrogen since the sanitized urine is not buried in the application (or else it is necessary to carry out a ground work / burial after the application). However, this tool is very suitable for the application of “stabilized” urinofertilizers, i.e. for which the nitrogen is not in volatile form (i.e. not in the form of ammonia but preferentially in the form of nitrates). We will not detail this technique, but it is possible to obtain urine stabilised by nitrification, and in particular thanks to a low-tech process developed by Aneco (<https://an-eco.ch/>): the Pitribon (ANECO 2024)..

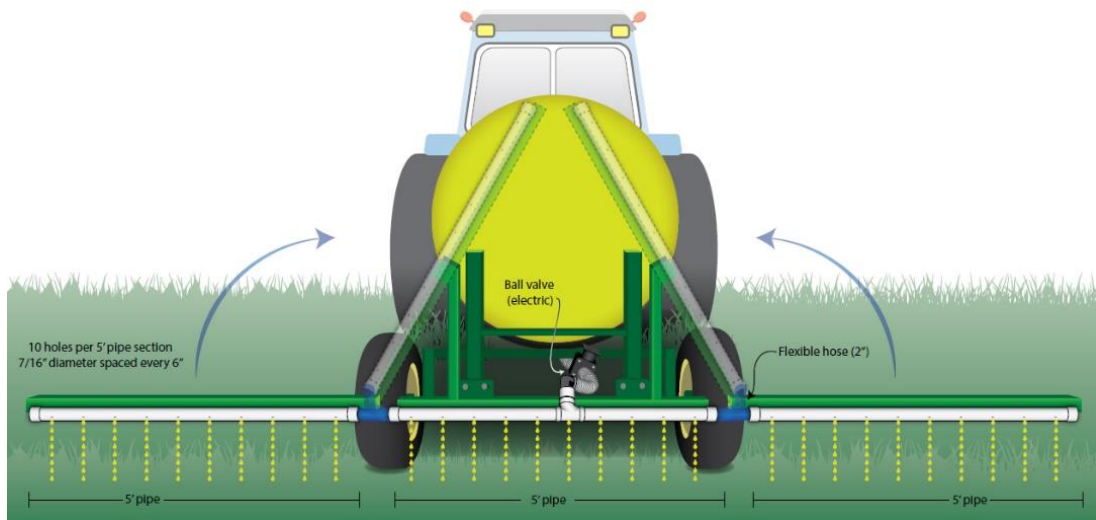

Figure 6 :: Self-constructed stabilised urine spreader from the Rich Earth Institute (Table 2019) for use in arable crops and grassland. Source: Rich Earth Institute



Figure 7:: Photos of the Rich Earth Institute's self-constructed stabilised urine spreader, in use. Source: Rich Earth Institute.

### Ferment injector (self-constructed)

We have identified other cases where farmers are trying to inject liquid into the soil: it concerns the application of ferments and/or microorganisms. We did not find any machines on the market for

these uses, but we identified self-constructed models, from existing machines, to carry out these injections into the soil.



Figure 8 :: Grazing cracking and fermentation injection with a modified machine. Credit P.S Calvados / Ulrich Schreier (Schreier 2021)

This photo (Figure 8 above) shows the use of two combined elements (sprayer, front, and soil working tool, rear) to bury the liquid in the soil.



Figure 9 Teeth with injectors. Credit: Eco-Dyn (Eco-Dyn s. d.)

These two tools are interesting because they show that it is possible to easily modify existing tools in order to inject the sanitized urine into the soil.

**THIRD part**

**Design of an injection tool for fertilized urine on  
raised bed**

## 6. Why develop a specific machine?

Context of machine development and technical choices

We tested fertilization with sanitized urine with the farm partner of the Enville project. This enabled us to identify the existing tools for carrying out these applications but also to identify “missing” tools for applying the sanitized urine under certain conditions. Indeed, we did not have the practical tools to fertilize crops that were not equipped with a drip irrigation system, that is to say, open-field crops and a good part of the crops on beds (often irrigated by spraying).

However, the farm we worked with was particularly interested in fertilizing crops grown under these conditions: leeks, cabbage, potatoes, beets, etc. Furthermore, the fertilization of these crops seemed particularly interesting to us to carry out with undiluted sanitized urine applied once before sowing or planting. This allow a delay of more than one month between the last fertilization and the harvest, according to the WHO recommendations on this subject (WHO 2012; Richert, Gensch, and Jönsson (2011).

The partner farm of the Enville project was already equipped with a tractor and we wanted to be able to attach a machine to it to inject the sanitized urine into the ground before planting or sowing, on a vegetable beds. The injection makes it possible to limit volatilization to the maximum, and therefore the nitrogen loss and the odours.

The tool that we developed is therefore intended for farms in diverse market gardening, beds, between 80cm and 1m20 wide, and equipped with a tractor of about 40HP.

- Selected technical route

We have defined the fertilization the basis of several essential parameters: find a way to inject the urine into the soil to reduce volatilization and biological health risks structurally and reduce the time required to complete the application.

In the context of market gardening where soils are prepared with towed tools, it seems appropriate to come and carry out fertilization after this preparation or just before sowing/planting. The injection of the sanitized urine into the soil makes it possible not to have to make an additional operation to cover the product after its application, as is done in certain contexts, in particular in field crops, after passage through slurry dribble bar.

The application of undiluted sanitized urine, in one go, makes it possible to limit the working time associated with the application of the fertilizer. In addition, the application on bare soil (before sowing or planting) gives us all the freedom to open the soil for injection.

For a leeks (for instance), we also thought about the possibility of applying the sanitized urine at the time of earth up, since this action requires the passage of a disk which covers the base of the leeks with earth. The application could take place just before the earth covering to bury the sanitized urine. However, we have not developed such a tool or tested this route.

We have not (yet!) worked on solutions adapted to non-mechanised market gardening and non-soil working farms. We hope to carry out specific work on this in the coming years, subject in particular to obtaining the necessary funding.

## 7. Overview of the tool being developed

We have developed several tools to be coupled to a tractor, to bury the sanitized urine in the ground before planting or before sowing. The tools are licensed under CC BY NC SA. In order not to overload this document, the detailed instructions for assembly and maintenance are presented in another document available on the OCAPI website:

<https://www.leesu.fr/ocapi/les-projets/enville/outils-agricoles/>

The aim was to bury the sanitized urine in the ground, and we sought to transform the soil-working tools, particularly the vibrocultivator, on which the sanitized urine application pipes would be fixed, also combined with a tank and a motor-driven pump.

The name chosen for the first tool developed is the Pipiculteur: it has been thought of as a sanitized urine (or **pipi**) landfill mixing the characteristics of **vibrocultivators**, cultivators, and spreaders.



Figure 10 Vibroculteur (Credit Agrieuro)



Figure 11 Farmer (Credit Agrieuro)



Figure 12 Spreader (Credit Agrieuro)

When designing the tool, we considered using second-hand elements. However, in order to facilitate prototyping and to offer a replicable tool, we have prioritized equipment that is commercially available or based on simple self-construction. We have also made choices to reduce the cost of the tool, and we strongly encourage people who can to modify equipment already on their farm to make other machines.

The first prototype was designed in a modular manner so as to be able to test different burial tools. The Pipiculteur consists of several elements:

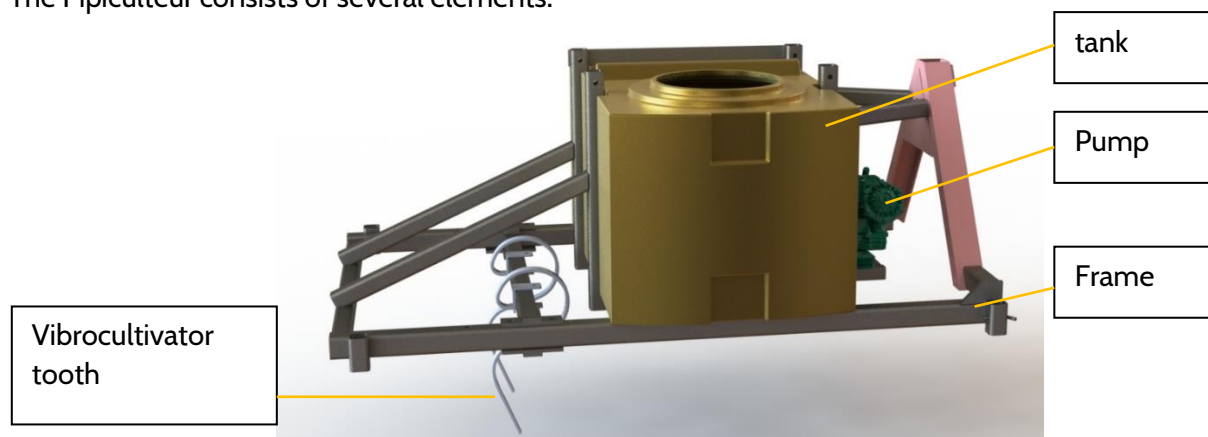

Figure 13 :: 3D Modelling of the Pipiculteur

The frame is inspired by the vibroplanche of Atelier Paysan (<https://latelierpaysan.org/Vibroplanche>). It consists in particular of a hitch triangle and a support for the pump and the tank. In the first version of the Pipiculteur, the teeth are mounted on a removable transverse bar. This makes it possible to fit a 50x50mm cross-section bar adapted or in 80x80mm.

- A **spray pump** that is connected to the tractor power take-off with a universal shaft. This pump is used both to fill the tool tank, inject the sanitized urine and empty the tank at the end of use. A distributor and the motor speed changes make it possible to adjust the flow rate of the injected sanitized urine.
- A **400L tank** that allows to transport the sanitized urine at the same time as the tool.
- **Vibrocultivator teeth** attached to a pipe are used to inject the sanitized urine into the ground.
- A **piping system** that allows, thanks to a valve system, to fill, empty and clean the tool (not shown in 3D above). The diagram below shows the circulation of sanitized urine in the Pipiculteur

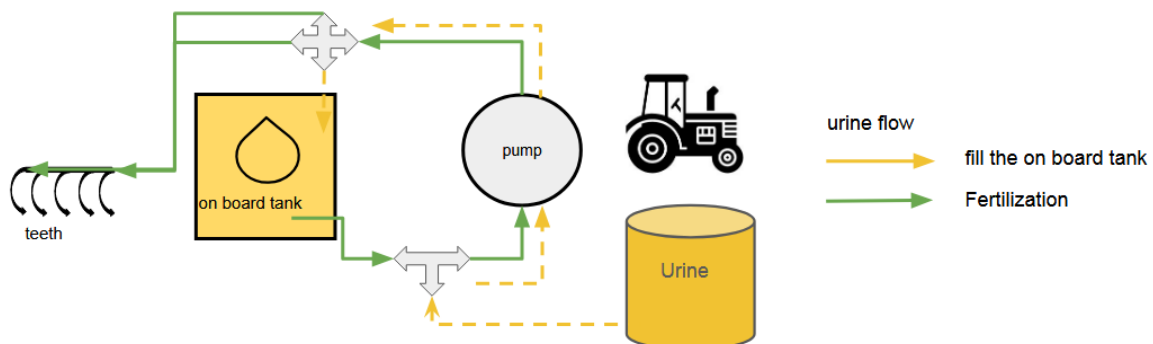

Figure 14 Flow diagram of sanitized urine in the Pipiculteur

## 8. Technical description and choices

### 8.1. Reuse of a sprayer?

Initially, we thought we would buy a sprayer body and transform it so we could weld teeth to inject the sanitized urine. This choice was soon abandoned as the sprayers were expensive and the frame were not strong enough to do soil work.

However, there are some very interesting features that can be borrowed from sprayers, such as the presence of a **tool rinsing tank**, a **hand rinsing tank** and a **cone bottom** to avoid keeping any product in the tank. In the current version of the Pipiculteur, these elements are not integrated into the machine in order to reduce the total weight of the tool. The rinsing elements are nevertheless provided for in the use of the tool but they must be brought to the site during fertilization.

## 8.2. tanks(s)

In discussions with several farmers and considering the capacities of their tractors, we set a maximum weight of the tool at 500/600 kg. By estimating the weight of the vacuum tool, we therefore started with an on-board capacity of 400 litres.

For the on-board tank we needed the following characteristics:

- Rigid tank
- Sufficiently strong in case of impact
- Made of a material that does not react with sanitized urine
- Ability to drill using wall passes.

We selected the model on the other side because it met all the criteria.

We also used a 1000L IBC-type tank to store urine at the end of the field and fill the on-board tank if necessary. In the case of a tractor with a fork, this tank can be used to feed the pump directly. This reduces the number of transfers required to make fertilization, but be careful of the fork-lifting capacity (full IBC tank = 1 ton).

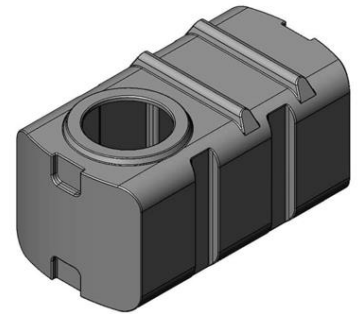

Figure 15 3D representation of the tank



Figure 16:: use of tractor forks to accommodate the volume of sanitized urine (alternative to the tank integrated in the tool)

## 8.3. Pump

The pump installed in the machine is used both to fill the on-board tank before spreading and to send the sanitized urine into the injection pipes in the ground during spreading. We needed the following features:

- Resistance to chemicals such as sanitized urine (strongly corrosive because it is rich in ammonia)
- Starting from the power take-off of the tractor
- Ability to connect multiple pipes at the outlet
- High flow rate (minimum 60L/min but ideally above 80L/min)
- Low outlet pressure

- Self-priming
- Lifting height of at least 1m

We chose a pump model after a discussion with a farm supply salesman. It is certain that there are other models available for this use.

A distributor at the pump outlet as well as different power take-off speeds allow us to choose all injection flow rates between 15L/min and 100L/min.

#### 8.4. Teeth

In order to dig a furrow to deposit the sanitized urine we have chosen to use vibrocultivator or cultivator teeth. We then secured the sanitized urine inlet pipes behind the teeth with solid tape (the "gaffer" type). In the photo below the pipes are attached a bit "high" and can be placed lower on the tooth.



*Figure 17 Vibrocultivator teeth with the Lisain inlet pipe (which can be fixed lower than in this photo)*

A disk or deflector can be added to close the furrow after sanitized urine has been applied. During our tests, we found that fine soil preparation allows the furrows to close on their own after the teeth have passed through them. Thus, we did not attempt to add a disk to mechanically close the Furrows. However, this seemed important to us for application on a soil that still had large lumps (see paragraph "11.1 Preparation of the soil").



*Figure 18.: On the left, use the tool on a coarsely prepared floor: the furrows could not close on their own and we observed volatilisation (odours). On the right, the soil was prepared in a fairly fine manner, the Furrows closed on their own after the teeth had passed and we observed few odours.*

## 8.5. Frame

Taking into account the elements mentioned above, we have designed a steel frame. It is mechanically welded and its manufacture is quite simple. We were inspired by the [vibroplanche](#) of Atelier Paysan.

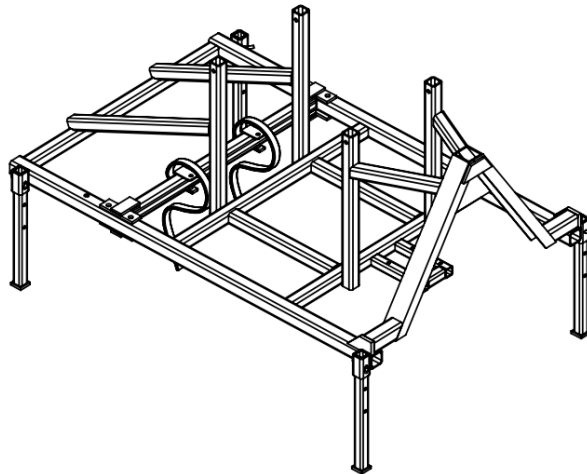

*Figure 19 A 3D representation of the Pipiculteur frame*

## 8.6. Piping

To choose the piping elements we have defined the essential functions for a correct use of the Pipiculteur:

- Fill the on-board tank from the IBC “at the end of the field”
- Fill the on-board tank from "end-of-field" containers
- Send the sanitized urine to the teeth from the onboard tank
- Send the sanitized urine to the teeth from the IBC tank “on the forks”
- Empty the on-board tank in cans or in the IBC tank

The system has been designed so that all these steps can be carried out with the same pump, the motor-driven pump mounted on the tool and connected to the power take-off of the tractor.

In addition to these essential functions, it is very important in any project on manure fertilization to reduce as much as possible the risks of overflows, projections and contact with operators. The use of quick couplings and valves on pipes can reduce exposure. In addition, it is important to wear suitable protective equipment (see “Protective equipment” section).

We then chose the different pipes and fittings depending on the characteristics of the IBC pump and tank. The components of the machine are described in detail in the instructions for manufacture and use. Below is the diagram of the sanitized urine flows for the filling of the tank and fertilization.

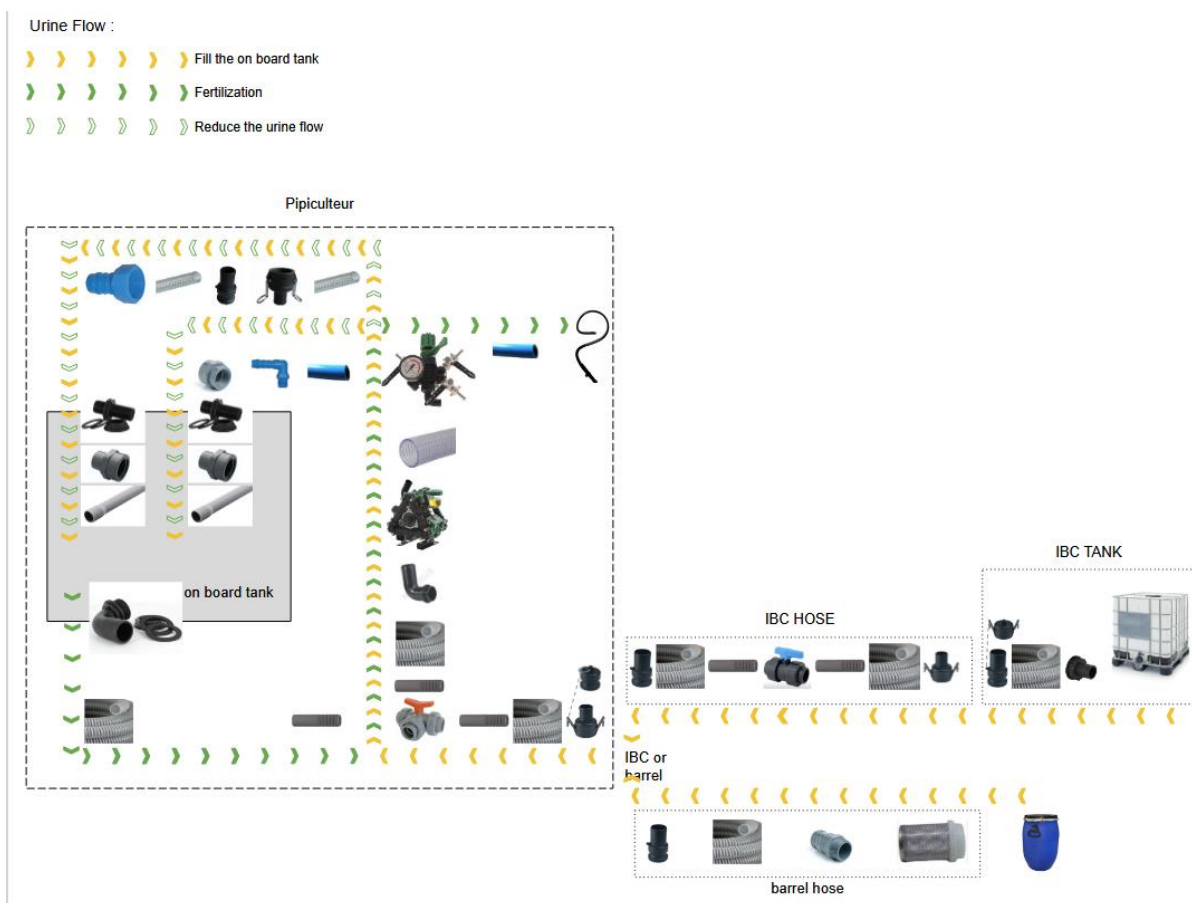

Figure 20 :: Diagram of the circulation of the sanitized urine in the Pipiculteur. The on-board reactor tank is filled and the sanitized urine is applied to the ground using the same pump: it is the orientation of the valves that gives the direction of operation of the pump.

## 8.7. Areas for Improvement

Following the fabrication of a first prototype of the Pipiculteur, we have made slight improvements. The plans we publish include these changes.

Here are also some additional suggestions for improvements or modifications not included in the published plans.

### Tank 400L or 500L

The tank we have chosen does not have a tight lid. It is therefore recommended to **not** fill it completely in order to avoid overflow due to shaking when travelling with the tractor.

It is possible to fit a 500L tank (instead of 400 L) and fill it according to the lifting capacities of the tractor. This would involve modifying the position of the reinforcements on the chassis and therefore would affect the total width of the machine.



*Figure 21 Tank 500 L possible for the Pipiculturist*

### Pump rinsing tank and handwashing machine

To increase the service life of the components and prevent the pipes from clogging, it is recommended that the pump and tank be cleaned with water after each use. It may be advantageous to weld a structure on the chassis in order to fit a 20L bottle to facilitate this cleaning.

A hand-cleaning can also be easily installed, especially a can already equipped with a tap.

Be careful, the addition of these elements increases the total weight of the machine. For the prototype we have chosen not to put them so that the machine can be used by as many tractors as possible.

### Deflector

If the soil is worked before fertilization and the lumps are small enough, the Furrows close immediately after the teeth have created them. During our tests, we did not use tools to close the furrows but it is easy to add a deflector, a disk for example.

If the Pipiculteur is used in a technical route that does not include extensive soil preparation, we recommend mechanically closing the Furrows with disks or deflectors.

### Grinding wheels

The rear props can be replaced with wheel-set wheels to make it easier to adjust the working depth.

## 9. Regulation on tools used in agriculture

### 9.1. Approval

The Pipiculteur is not subject to road approval because it is a portable tool.

According to the Chamber of Agriculture of Loiret: 'For the vast majority of agricultural machinery to be used on the roads, road approval is required (also referred to as 'road approval'). Only tools worn and towed vehicles less than or equal to 1.5 tons of PTAC are excluded.' (DESEAU 2021)..

## 9.2. EC certification

According to l'Atelier Paysant, a cooperative for the self-construction of agricultural equipment: 'The certification procedure for agricultural machinery which applies to large manufacturers also applies to self-constructing operators who provide machinery designed and built by them. It must comply with the essential health and safety rules that apply to all machinery placed on the European market. In order to justify, under his responsibility, the conformity of the machinery, he must draw up a set of documents described below. The obligatory formalities for self-certification are defined in the European Directive 2006/42/EC transcribed in the Labour Code (Articles R 233-73 to R 233-76)." More information on self-certification is available on the website of the Atelier Paysan (<https://latelierpaysan.org/Techniques-securite-reglementations>).

The Pipiculteur is considered to be a machine because it comprises a pump that is driven by the tractor engine. Each manufacturer of a Pipiculteur is therefore responsible for building a machine that complies with the European construction rules, and for self-certifying it according to the procedure described by Atelier Peasant.

We provide you with a self-certification file template, based on the two machines we built and self-certified. You will need to adapt these models to the technical details of the machine you actually built. The dossier is available for download on the OCAPI website (<https://www.leesu.fr/ocapi/les-projets/enville/outils-agricoles/>) and consists of:

- the instructions for the machinery
- the "Farmer Certification File" document
- the EC declaration of conformity.

As we do not know the regulation for other countries than France, we provide these documents only in French. We also ask the future manufacturer of Pipiculteur to check and comply with local regulations.

## 10. Variations of the tool without the on-board tank

It is possible, if the tractor allows it, to use a 1000 L tank (e.g. IBC) carried by the forks at the front of the tractor. This makes it possible to work with a greater volume of sanitized urine and thus to reduce the return flow of filling during spreading. For these variants, we therefore propose removing the tank from the frame at the rear, which makes it possible to reduce its size, its weight, the necessary manufacturing time and makes it easier to transport from one farm to another.



Figure 22.: Example of IBC tank at front of tractor

However, at the time of writing this report, the options with the front tank of the tractor were not tested in real conditions.

For variants without on-board tanks, the advantages are numerous (lower weight, dimensions and costs), but they require a suitable tractor.

#### Tank-less farmer

This variant reproduces the structure of the Pipiculteur by removing the on-board tank part.

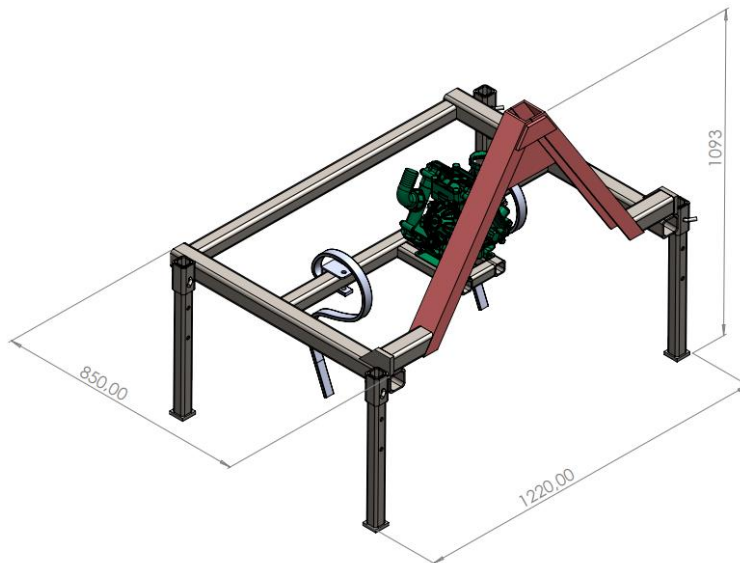

Figure 23 :: Dimensions in mm of the Pipiculturist without tank

#### Coupling triangle with pump

This variant is in fact an adapter between the tractor and an already existing soil working tool (vibrocultivator, cultivator, tool holder bar, etc.). Please note that the design of this adapter has not been finalized during the drafting of this report (reinforcements are missing between the two triangles).

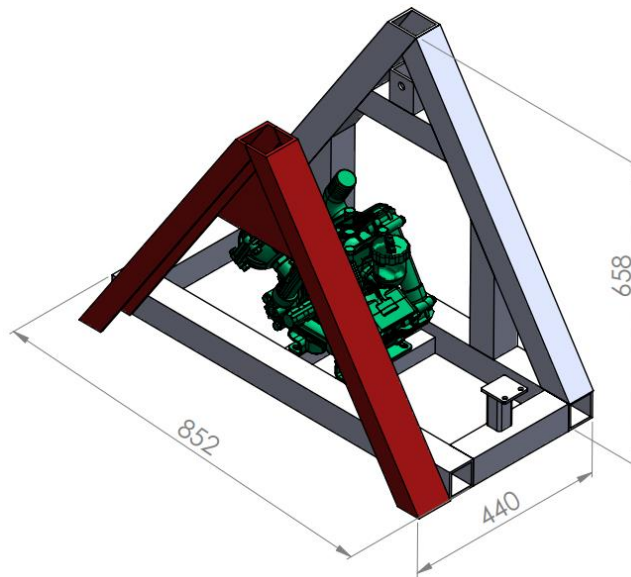

Figure 24 Triangle adapter dimensions (in mm)

Removable pump on existing cultivator or vibrocultivator

For people who already have a floor working tool, it is possible to weld a pump support onto their tool, or to create a system that allows the pump to be attached to it when needed. This option is the most time- and money-saving.

We did not design this module because it depends on each tool. But the fabrication is quite simple.

## 11. Use

Complete explanations on the use of the tool are given in the instructions for manufacture and use, available on this link: <https://www.leesu.fr/ocapi/les-projets/enville/outils-agricoles/>

### 11.1 Preparation of soil

As explained above, the sanitized urine must be injected into the soil, covered after application, in order to limit volatilization as much as possible. This practice also makes it possible to limit structurally the biological health risks. We did several tests, the first with rapid soil preparation and the presence of large lumps and the second with larger soil preparation and much smaller lumps.

In the first case, part of the sanitized urine was thrown into the open because the lumps were too large to cover the furrow properly. The smell of ammonia also told us that there was volatilization.

In the second case, we were able to visually verify that the floor closed properly after the tool had passed. Moreover, there was no smell.



*Figure 25 :: On the left, use of the tool on coarsely prepared soil (many large lumps and residues): the Furrows did not close on their own after the teeth had passed and we observed volatilization (odours). On the right, the soil was prepared in a fairly fine manner, the Furrows closed on their own and we observed little volatilization (few odours).*

For these tests, we fertilized with sanitized urine just before sowing or planting so that we did not have to rework the soil after fertilization. The conditions required for good fertilization are substantially the same as for the use of a seed drill or a potato planter, so we did not have any specific preparation steps for fertilization, which was one of the objectives in order to limit the working time related to this fertilization.

## 11.2. Adjusting the Sanitized urine Injection Rate

The design and use of this tool is relatively simple and low-tech, which is why there is no automatic sensor or regulator for the flow injected into the ground. It is therefore necessary to know the pump flow rate and the tractor advance speed to know the volume of sanitized urine injected into the ground.

Initially, it is necessary to make a non-injection use to know the speed of the tractor and the time to prepare the field length . For example, in speed "Turtle 2" we cover a board of 50 m in 60 sec (3 km/h).

To have a concentration of 2 L/m<sup>2</sup> it is therefore necessary to set a pump flow rate of 100 L/min.

We made a chart to determine the pump flow rate (L/min) as a function of the tractor speed (km/h), for the different doses of sanitized urine:

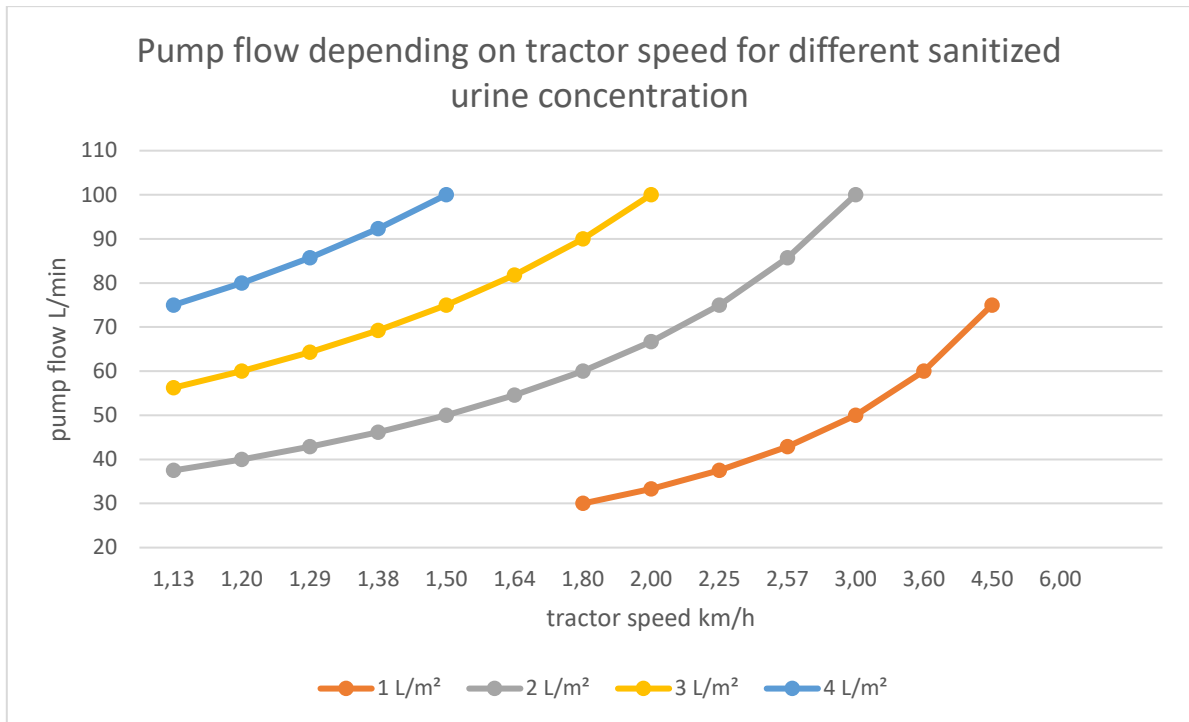

### 11.3. Tool operation and sanitized urine flow

The first step is to fill the on-board tank with sanitized urine, from the urine stock (e.g. IBC tank) and using the tool's motor pump. By opening and closing valves, this same pump will then be used to feed the pipes connected to the teeth of the tool, to fertilize the board.

## 12. Cost of tool

Here is the cost of the equipment, without labour or consumables (welding rods, disks, etc.). Details of the parts needed are available on the manufacturing instructions (prices in November 2024).

Version with tank on the frame:

Type	TTC Price
shaft	€95.42
Tank	€199.00
Teeth	€60.00
Metal	€436.90
Pump	€480.15
Hardware	€40.00
Piping - Fittings	€338.16
<b>Grand Total</b>	<b>€1,649.63</b>

No-tank version on the frame:

Type	TTC Price
shaft	€95.42
Teeth	€60.00
Metal	€250.78
Pump	€480.15
Hardware	€40.00
Piping - Fittings	€165.43
<b>Grand Total</b>	<b>€1,091.78</b>

## **FOURTH PART**

### **Fertilization tests and diffusion**

## 13. 2024 test campaign

### 13.1. Tests

In 2024, we conducted simple sanitized urine injection tests. The primary goal was to verify the correct operation of the Pipiculteur. These tests were carried out on a market garden farm in Ile-de-France on plots not intended for the production of vegetables for the farm. There were two experimental plots, one 50x25m (16 bed) non-irrigated and one 50x7m (4 bed) irrigated.

It was planned that the farmers who left the plot available to us would not be involved in crop maintenance. So we chose to grow mustard (no maintenance) on 14 beds, as well as beetroots (moderate maintenance) on 2 beds and potatoes on 2 beds (low maintenance).

For all the tests we used 2 vibrocultivator teeth to inject the sanitized urine but it is possible to put more teeth to distribute more fertilized areas. A minimum distance between the teeth and good soil preparation should be respected to avoid jamming.

#### Parcel 1 - Mustard:

On this plot we started from a meadow. We passed different soil working tools before using the pipiculteur.

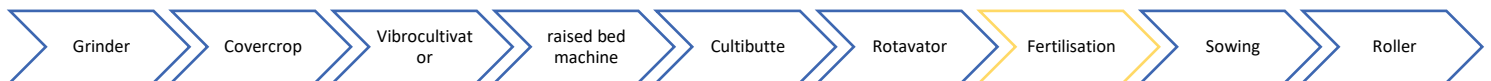

Figure 26 :: Technical itinerary of our mustard test

We alternated beds with fertilization at 2L/m<sup>2</sup> of sanitized urine and beds without fertilization. We then sowed white mustard by hand (on 14 boards) before passing a roll.

#### Parcel 2 - Beetroot and potatoes:

This parcel was prepared in autumn 2023 by the farm's market gardeners (6 months before that). We did a simple soil job in addition. We started with beets. During sowing we realised that the lumps were a bit too big, we decided to pass the rotavator before planting the potatoes.

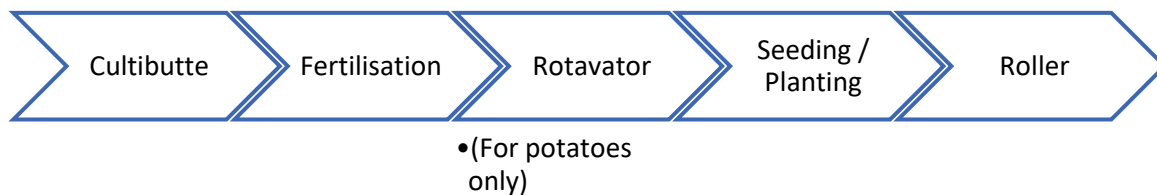

Figure 27 :: Technical itinerary for our potato and beetroot tests

For beets, we made a mixture of two varieties, Robuschka and Formanova. We have organised two collective weed control projects with members of the OCAPI research programme. It should be noted that wild plants also benefited from fertilization on the sanitized urine and that they grew more on the fertilized board (visual observation).

For these boards, we have no information on fertilizations from previous years.



Figure 28 :: Difference in growth on wild plants with and without sanitized urine

For potatoes, we also did a crop ridging and a manual weeding. We planted these potatoes quite late (June 11), so we chose the Cherries because this variety grows quite quickly.

### 13.2. Results

#### Mustard

The purpose of this test was to visually check the correct functioning of the Pipiculteur and the effects on the crops.

We did not harvest the mustard and it is expected that this parcel will become a meadow again from next year.

In the photo below, we can clearly see the positive effects of the sanitized urine on mustard growth



Figure 29 :: Parcel of mustard 3 weeks after sowing

The photo below also shows the differences between cultures with and without sanitized urine.



Figure 30 :: Parcel of mustard 6 weeks after sowing

For this test, it would have been interesting to measure the area affected by the sanitized urine and to compare it with the distance between the teeth so as to know the number of injectors needed for the next tests.

### Beetroot

We harvested the beets at the end of September and weighed the crops on an area of 12m<sup>2</sup> per bed. During weeding, we took care to work in parallel on the two boards so that beets with and without sanitized urine grow under the same conditions.

The following results were obtained:

	sanitized urine	No sanitized urine
Average weight per 100 beets	238 g	190 g
Total weight harvested on 12m <sup>2</sup>	44 kg	28 kg

On average, we observe a positive effect of sanitized urine on beets but it is difficult to conclude precisely on this sample from the increase in yields. Indeed, beetroot is a crop that has a large variation in size on the same board. In the photo below, we can see the difference between one of the largest beets harvested and one of the smallest. Both come from the bed without fertilization. More beds and more beets should be tested.



Figure 31 :: Two beets from the board without skate

## Potatoes

As for potatoes, we harvested very small quantities, on boards with and without sanitized urine. This can be explained by several factors:

- We planted the potatoes quite late in the season
- There was little weeding during the season because we focused on beets
- There have been no actions against the Colorado potato beetle.
- The weather was not favourable in the summer of 2024 and the farmers who hosted us for our trials also had low yields
- The soil was very moist during the harvest and so we used only the surface lift.

We collected 12.5 kg on 25m<sup>2</sup> with and without sanitized urine, which is very small. We are not able to conclude on this culture.

### 13.3. Collection and awareness of the subject of urine valorization

We have not carried out any agronomic trials. However, the fertilizing efficiency of the sanitized urine has already been proven in numerous publications (32, 11, 41).

The tests that we have carried out are nevertheless essential, firstly to verify the operation of the machine and secondly as a demonstrator. For example, the farmers who provided us with their welding workshop and plots of land for our tests did not necessarily want to use urine based fertilizer before the tests. Having seen the different results (visual effects), they are now considering incorporating the manure into their fertilization practices.

The harvested beets and potatoes will be offered for tasting as a medium to raise awareness of the agricultural valorization of urine and the cycle of nutrients. Indeed, it is always more fun and impactful to be able to show, tell or even taste, and to know that the practice already exists in some farms! For example, we gave the fertilized vegetables to the members of the AMAP of the farm that



*more successful than others!*

welcomed us. The AMAP members were generally very interested in this topic and several people expressed their desire to create a voluntary urine supply deposit for their neighborhood (see ENVILLE project, report and practice sheets). We then proposed the beets in self-service explaining the project to the AMAP members, of the farm that welcomed us for our trials. Their enthusiasm for this subject can be seen in the photo on the right, because at the end of the distribution, there were almost no beets left fertilized on the sanitized urine, whereas there were unfertilized beets left.

We plan to continue this awareness with the other AMAPs on the farm.

## Conclusion

The design and manufacture of the Pipiculteur allowed us to test fertilization with sanitized urine under real growing conditions, on a market garden bed by injection into the soil. The development of this tool complements the Enville project which seeks to foster the development of citizen networks. The project has also already developed tools and protocols for carrying out the other stages of the pathway (collection at home, voluntary urine supply points, logistics for transporting urine on the farm, etc.), in collaboration with a group of volunteer inhabitants. Details of these items can be found on the project page: <https://www.leesu.fr/ocapi/les-projets/enville/>.

We designed this tool to be low-tech, open-source, the simplest to manufacture and use, while respecting three fundamental points: user safety, the problem of volatilization related to the use of sanitized urine (= urine hygienized by storage) and the proper management of biological health risks in a multi-barrier logic. For the sake of the widest possible distribution, we did not use second-hand equipment but it is quite possible to use equipment already present on the farms.

We strongly invite all interested parties to download the drawings of this machine, to build it, to modify it or to create others. If you have any questions or ideas for improvement, you can contact us at: [enville@enpc.fr](mailto:enville@enpc.fr). Also, we will soon be publishing a website dedicated to the development of citizen networks.

Finally, we'd like to lend the functional prototypes to collect different feedback from professionals. So if you want to test the machine but are not able to manufacture your own, do not hesitate to contact us as well.

## Acknowledgements

I thank all those who have contributed to this project humanly and financially.

Thanks to Louise and Fabien for creating a position of welder-farmer-scientist.

Thank you to the farm who provided us with a workshop and land to do our experiments as well as to all the people who helped with the planting and maintenance of the crops.

Special thanks to the OCAPI team for hosting the weed control session.

Je n'ai pas vérifié les ref !

## References

- Agricultural Uses for Urine Fertilizer: Rich Earth Summit 2021.* 2021. <https://www.youtube.com/watch?v=nZqG2hdS2p8> (7 December 2023).
- ANECO. 2024. "The filter in Pitribon". [https://an-eco.ch/wp-content/uploads/2024/12/Affiche\\_A1\\_Pitribon.pdf](https://an-eco.ch/wp-content/uploads/2024/12/Affiche_A1_Pitribon.pdf).
- ARCEAU, Île-de-France. 2023. 'REGULATORY ISSUES RELATING TO THE SEPARATION AT SOURCE OF URINE AND FAECAL MATERIALS FOR AGRICULTURAL RECOVERY'. [https://www.leesu.fr/ocapi/wp-content/uploads/2023/03/NOTE-GTT-S%C3%A9paration\\_web\\_230330.pdf](https://www.leesu.fr/ocapi/wp-content/uploads/2023/03/NOTE-GTT-S%C3%A9paration_web_230330.pdf).
- Atlee, Jennifer. 2019. Rich Earth Institute: Community Guide". <https://richearthinstitute.org/urine-diversion-guide/> (4 December 2023).
- BERTRAND, Nathalie, Patricia BLANC, Pascal CAZIN, Céline DEBRIEU-LEVRAT, Virginie KLES, and Sophie PLANTE. 2023. *Experience feedback on water management during the 2022 drought*.
- Bes de Berc, Laureline, Florian Christ, Cyril Flamin, and Florent Levavasseur. 2021. *Use of digestate in agriculture - Good practices to be implemented*. ENGIE, INRAE, AAMF, AgroParisTech, ATE, ACE Methanisation.
- Billen, Gilles, Eduardo Aguilera, Rasmus Einarsson, Josette Garnier, Simone Gingrich, Bruna Grizzetti, Luis Lassaletta, Julia Le Noë, and Alberto Sanz-Cobena. 2021. 'Reshaping the European Agro-Food System and Closing Its Nitrogen Cycle: The Potential of Combining Dietary Change, Agroecology, and Circularity'. *One Earth* 4(6): 839-50. doi:10.1016/j.oneear.2021.05.008.
- DESEAU, Sylvain. 2021. 'Registration of agricultural vehicles'. [https://paca.chambres-agriculture.fr/fileadmin/user\\_upload/Provence-Alpes-Cote\\_d\\_Azur/O2O\\_Inst\\_Paca/CA04/Documents/Actualites/Archives/2021/Immatriculation\\_machine.pdf](https://paca.chambres-agriculture.fr/fileadmin/user_upload/Provence-Alpes-Cote_d_Azur/O2O_Inst_Paca/CA04/Documents/Actualites/Archives/2021/Immatriculation_machine.pdf).
- Eco-Dyn. *Production of the regenerative ferment: instructions for use*. [https://vernoux.org/agriculture\\_regenerative/Elaboration\\_du\\_ferment-regenerateur.pdf](https://vernoux.org/agriculture_regenerative/Elaboration_du_ferment-regenerateur.pdf).
- Esculier, Fabien. 2018. "The food/excretion system of urban areas: socio-ecological regimes and transitions." phdthesis. University Paris Est. <https://hal.science/tel-01787854> (4 December 2023).
- Etter, Bastian, Kai M. Udert, and Teddy Gounden. 2015. *VUNA: Recovery of Urine Nutrients. Promoting Sanitation & Nutrient Recovery through Urine Separation. Final Project Report 2015*. ETH Zurich. Postponed. <https://www.research-collection.ethz.ch/handle/20.500.11850/107991> (4 December 2023).
- Fabien, ESCULIER, HOUOT Sabine, LEVAVASSEUR Florent, MARTIN Tristan, DESCHAMPS Marjolaine, AUBRY Christine, BRUN Florent, AUBIN Joël, and Project Agrocapi. "Agrocapi Project - Study of agricultural value chains for urinofertilizers. Final Report.": 2022

- FNAB. 2024. *From toilets to fields: should organic soils be fed with human waste? RESULTS OF THE FNAB SURVEY OF ITS MEMBERS.* <https://www.produire-bio.fr/wp-content/uploads/2024/11/RESULTATS-ENQUETE-FNAB-MONA-Excretats-2.pdf>.
- The Peasant Workshop. 2024. 'Vibroplaiçe'. <https://latelierpaysan.org/Vibroplanche>.
- de Looze, Renaud. 2018. *Urine, from liquid gold to garden - A practical guide to produce fruit and vegetables using local urine and compost.* Terran. <https://www.terran.fr/produit/71/9782359811001/l-urine-de-l-or-liquide-au-jardin> (4 December 2023).
- Marandet, Odile, and Fabien Esculier. 2022. *Analysis of the obstacles and levers to the use of human excretes in organic farming.*
- Martin, Tristan M. P., Fabien Esculier, Florent Levavasseur, and Sabine Houot. 2020. Human urine-based fertilizers: A review'. *Critical Reviews in Environmental Science and Technology* 52(6): 890-936. doi:10.1080/10643389.2020.1838214.
- Muller, Adrian, Christian Schader, Nadia El-Hage Scialabba, Judith Brüggemann, Anne Isensee, Karl-Heinz Erb, Pete Smith, et al. 2017. "Strategies for Feeding the World More Sustainably with Organic Agriculture". *Nature Communications* 8(1): 1290. doi:10.1038/s41467-017-01410-w.
- Nesme, Thomas, Benjamin Nowak, Christophe David, and Sylvain Pellerin. 2016. "Can organic farming develop without abandoning its ecological principle? The case of the management of mineral nutrients". *Agronomic Innovations*: np. doi:10.15454/1.4721176631543018E12
- WHO. 2012. "WHO Guidelines for the Safe Use of Wastewater, Excreta and Household Water." <https://www.who.int/fr/publications-detail/9241546859>.
- Richert, Anna, Robert Gensch, and Håkan Jönsson. 2011. 'Practical advice for the use of urine in agricultural production'.
- Schreier, Ulrich. 2021. *Cracking with lactic acid ferment injection: an effective tool for 3D agriculture.* The World of Regenerative Agriculture. [http://vernoux.org/agriculture\\_regenerative/La\\_fissuration\\_avec\\_injection\\_de\\_ferments\\_microbiens\\_un\\_outil\\_efficace\\_au\\_service\\_de\\_l\\_agriculture\\_3D.pdf](http://vernoux.org/agriculture_regenerative/La_fissuration_avec_injection_de_ferments_microbiens_un_outil_efficace_au_service_de_l_agriculture_3D.pdf).
- Starck, Thomas. 2024. 'Towards a Circular Management of Nitrogen and Phosphorus in Human Excreta: Current State, Global Agricultural Potential, and Spatial Constraint in France. National School of Roads and Bridges. <https://hal.science/tel-04727806> (16 January 2025).
- Tandia, Cheick Tidiane. 2006. "ECOSAN in schools, Petit Badien (Côte d'Ivoire)". *ECOSAN Info* (n°07). [https://www.susana.org/\\_resources/documents/default/2-1516-ecosan-info-no07-december-2006.pdf](https://www.susana.org/_resources/documents/default/2-1516-ecosan-info-no07-december-2006.pdf).
- Udert, K.M., T.A. Larsen, and W. Gujer. 2006. 'Fate of major compounds in source-separated urine'. *Water Science and Technology* 54(11-12): 413-20. doi:10.2166/wst.2006.921.
- Zandee, Marijn, Bastian Etter, and Kai M. Udert. 2012. *Risk of clogging of drip-line emitters during urine fertilisation through drip irrigation equipment.* [https://www.eawag.ch/fileadmin/Domain1/Abteilungen/sandec/schwerpunkte/ewm/STUN/Drip\\_pdfs/Urine\\_Fertigation\\_with\\_Drip\\_Irrigation.pdf](https://www.eawag.ch/fileadmin/Domain1/Abteilungen/sandec/schwerpunkte/ewm/STUN/Drip_pdfs/Urine_Fertigation_with_Drip_Irrigation.pdf).

**Photo and illustration credits: If not specified, the credit of the photos is Ocapì.**